



INTRODUCTION

This Honda Shop Manual Addendum contains information pertinent to the 1979 CX500.

Refer to the base Shop Manual for service procedures and data not included in this addendum.

ALL INFORMATION, ILLUSTRATIONS, DIRECTIONS AND SPECIFICATIONS INCLUDED IN THIS PUBLICATION ARE BASED ON THE LATEST PRODUCT INFORMATION AVAILABLE AT THE TIME OF APPROVAL FOR PRINTING. HONDA MOTOR CO., LTD. RESERVES THE RIGHT TO MAKE CHANGES AT ANY TIME WITHOUT NOTICE AND WITHOUT INCURRING ANY OBLIGATION WHATSOEVER.

NO PART OF THIS PUBLICATION MAY BE REPRODUCED WITHOUT WRITTEN PERMISSION.

HONDA MOTOR CO., LTD.
Service Publications Office

TABLE OF CONTENTS

- 1. GENERAL INFORMATION 21-2
- TORQUE VALUES 21-2
- MAINTENANCE SCHEDULE 21-3
- CABLE & HARNESS ROUTING 21-4
- 2. INSPECTION AND ADJUSTMENT 21-5
- BRAKE FLUID LEVEL 21-5
- BRAKE FLUID REPLACEMENT 21-5
- 3. FRONT WHEEL/SUSPENSION 21-7
- 4. HYDRAULIC DISC BRAKE 21-8
- SERVICE INFORMATION 21-8
- TROUBLESHOOTING 21-8
- MASTER CYLINDER 21-9



1. GENERAL INFORMATION

TORQUE VALUES

<ENGINE>

Item	Q'ty	Thread Dia. (mm)	Torque Values	
			kg-m	ft-lb
Crankshaft cap	7	8	2.0 - 2.4	14 - 17
Connecting rod cap	4	8	2.8 - 3.2	20 - 23
Cylinder head	8	12	5.0 - 5.5	36 - 40
Valve adjusting nut	8	6	1.5 - 1.8	11 - 13
Flywheel	1	12	8.0 - 10.0	58 - 72
Clutch center	1	20	8.0 - 10.0	58 - 72
Primary drive gear	1	12	8.0 - 9.5	58 - 69
Starting clutch outer	3	8	1.8 - 2.5	13 - 18
Cooling fan	1	8	2.0 - 2.5	14 - 18
Cam shaft sprocket boss	1	20	8.0 - 10.0	58 - 72
Cam shaft sprocket	2	7	1.6 - 2.0	12 - 14
Change pedal	1	6	1.0 - 1.4	7 - 10
Radiator drain bolt	1	12	0.15- 0.30	1.1- 2.2

<FRAME>

Item	Q'ty	Thread Dia. (mm)	Torque Values	
			kg-m	ft-lb
Steering stem nut	1	24	9.0 - 12.0	65 - 87
Front fork top bridge	2	7	0.9 - 1.3	7 - 9
Handlebar lock	2	6	1.0 - 1.4	7 - 10
Handlebar holder	4	8	2.5 - 3.0	18 - 22
Front fork steering stem	2	8	1.8 - 2.5	13 - 18
Front and rear axles	1	14	5.5 - 6.5	40 - 47
Front axle holder	4	8	1.8 - 2.5	13 - 18
Engine hanger bolt	4	10	3.5 - 4.5	25 - 33
Engine hanger bolt	1	12	6.0 - 7.0	43 - 51
Final drive flange nut	3	10	3.5 - 4.5	25 - 33
Rear brake torque link	1	8	1.5 - 2.3	11 - 17
Rear shock absorber	4	10	3.0 - 4.0	22 - 29
Foot peg	2	10	3.0 - 4.0	22 - 29
Swing arm pivot nut	1	23	8.0 - 12.0	58 - 87
Front brake disc	5	8	2.7 - 3.3	20 - 24
Gear case swing arm	3	10	3.5 - 4.5	25 - 33
Swing arm pivot bolt	1	23	0.8 - 1.2	6 - 9
Front caliper	2	10	3.0 - 4.0	22 - 29

Torque specifications listed above are for the most important tightening points. If a torque specification is not listed, follow the standards given below.

● STANDARD TORQUE VALUES

Item	Torque Values kg-m (ft-lb)	Item	Torque Values kg-m (ft-lb)
5 mm bolt and nut	0.45-0.6 (3- 4)	5 mm screw	0.35-0.5 (3- 4)
6 mm bolt and nut	0.8 -1.2 (6- 9)	6 mm screw	0.7 -1.1 (5- 8)
8 mm bolt and nut	1.8 -2.5 (13-18)	6 mm flange bolt and nut	1.0 -1.4 (7-10)
10 mm bolt and nut	3.0 -4.0 (22-29)	8 mm flange bolt and nut	2.0 -3.0 (14-21)
12 mm bolt and nut	5.0 -6.0 (36-43)	10 mm flange bolt and nut	3.0 -4.0 (22-29)



MAINTENANCE SCHEDULE

Perform the PRE-RIDE INSPECTION in the Owner's Manual at every maintenance period.

I : INSPECT, CLEAN, ADJUST, LUBRICATE OR REPLACE IF NECESSARY.

C: CLEAN

R: REPLACE

A: ADJUST

L: LUBRICATE

ITEM	FREQUENCY	WHICHEVER COMES FIRST ↓	ODOMETER READING [NOTE (3)]							REFER TO BASE SHOP MANUAL
			600 mi. (1,000 km)	3,750 mi. (6,000 km)	7,500 mi. (12,000 km)	11,250 mi. (18,000 km)	15,000 mi. (24,000 km)	18,750 mi. (30,000 km)	22,500 mi. (36,000 km)	
EMISSION RELATED ITEMS	ENGINE OIL	YEAR	R		R		R		R	Page 2- 2
	ENGINE OIL FILTER	YEAR	R		R		R		R	Page 2- 2
	CRANKCASE BREATHER	NOTE (1)		C	C	C	C	C	C	Page 3- 3
	AIR CLEANER	NOTE (2)		C	R	C	R	C	R	Page 3- 2
	* FUEL LINES				I		I		I	Page 3- 3
	SPARK PLUGS			I	R	I	R	I	R	Page 3- 3
	* VALVE CLEARANCE		I	I	I		I		I	Page 3- 4
	* CAM CHAIN TENSION		A	A	A	A	A	A	A	Page 3- 5
	* THROTTLE OPERATION		I		I		I		I	Page 3- 5
	* CARBURETOR- IDLE SPEED		I	I	I	I	I	I	I	Page 3- 6
	* CARBURETOR-CHOKE				I		I		I	Page 3- 6
	* CARBURETOR-SYNCHRONIZE		I		I		I		I	Page 3- 7
	* COOLANT				I		I		R	Page 3- 8 9- 3
	* COOLING SYSTEM, HOSES		I		I		I		I	Page 3- 8
	* RADIATOR CORE				I		I		I	Page 3- 8
NON-EMISSION RELATED ITEMS	* DRIVE SHAFT JOINT				L		L		L	Page 2- 3
	* FINAL DRIVE LUBRICANT				I		I		R	Page 2- 3
	BATTERY	MONTH	I	I	I	I	I	I	I	Page 3- 9
	BRAKE FLUID (FRONT)	MONTH 2 YEARS R	I	I	I	I	I	I	*R	Page 3- 9
	BRAKE SHOE/PAD WEAR			I	I	I	I	I	I	Page 3-11
	BRAKE SYSTEM		I		I		I		I	Page 3-11
	* BRAKE LIGHT SWITCH		I		I		I		I	Page 3-12
	* HEADLIGHT AIM		I		I		I		I	Page 3-13
	CLUTCH FREE PLAY		I	I	I	I	I	I	I	Page 3-13
	SIDE STAND				I		I		I	Page 3-14
	* SUSPENSION		I		I		I		I	Page 3-14
* NUTS, BOLTS, FASTENERS		I		I		I		I	Page 3-15	
** WHEELS		I		I		I		I	Page 3-15	
** STEERING HEAD BEARING		I		I		I		I	Page 3-15	

* SHOULD BE SERVICED BY AN AUTHORIZED HONDA DEALER, UNLESS THE OWNER HAS PROPER TOOLS AND SERVICE DATA AND IS MECHANICALLY QUALIFIED.

** IN THE INTEREST OF SAFETY, WE RECOMMEND THESE ITEMS BE SERVICED ONLY BY AN AUTHORIZED HONDA DEALER.

NOTE: (1) Service more frequently when riding in rain or at full throttle, or after being washed or overturned.

(2) Service more frequently when riding in dusty areas.

(3) For higher odometer readings, repeat at the frequency interval established here.



CABLE & HARNESS ROUTING

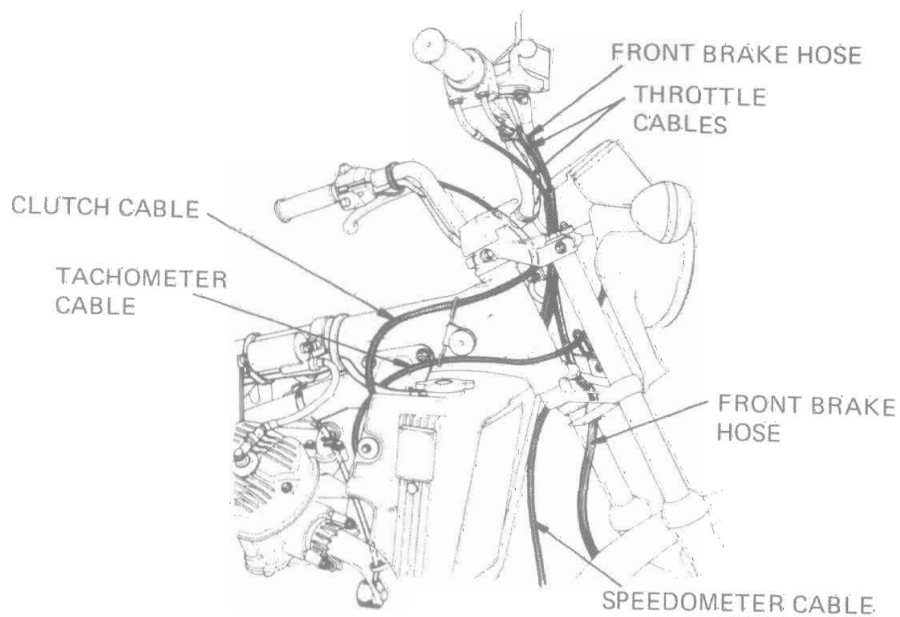
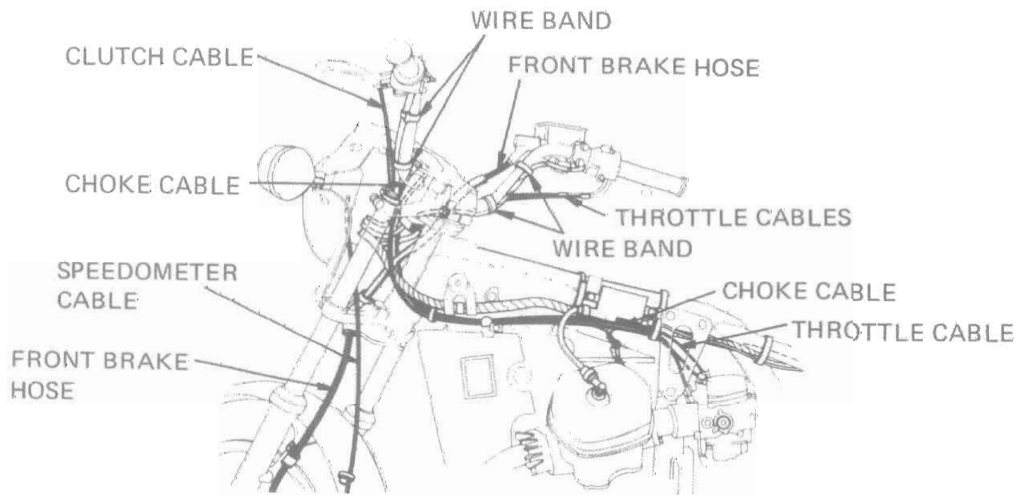
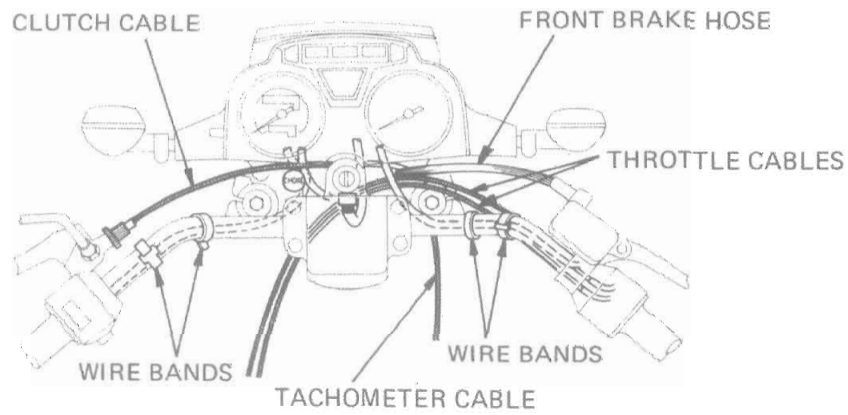



2. INSPECTION AND ADJUSTMENT

BRAKE FLUID LEVEL

Check that the front brake fluid reservoir is filled to the upper level mark.

If the level is lower than the upper mark, fill the reservoir with DOT-3 BRAKE FLUID up to the upper level mark.

Check the entire system for leaks, if the level is low.

CAUTION

- Do not remove the cap until the handlebar has been turned full left so that the reservoir is level.
- Avoid operating the brake lever with the cap removed. Brake fluid will squirt out if the lever is pulled.

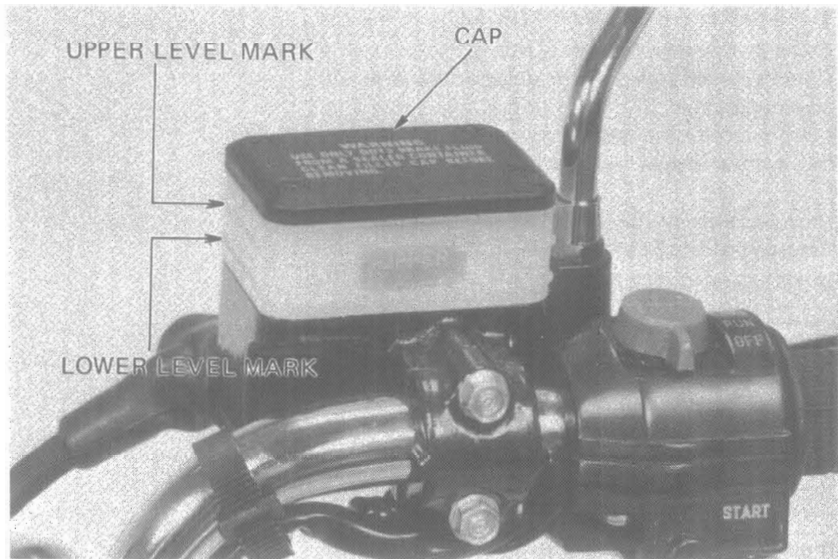

BRAKE FLUID REPLACEMENT

Check the fluid level with the fluid reservoir parallel with the ground.

CAUTION

Be sure to install the diaphragm on the reservoir when operating the brake lever to prevent fluid from squirting out. Avoid spilling fluid on painted surfaces. Place a rag over the fuel tank whenever the system is serviced.

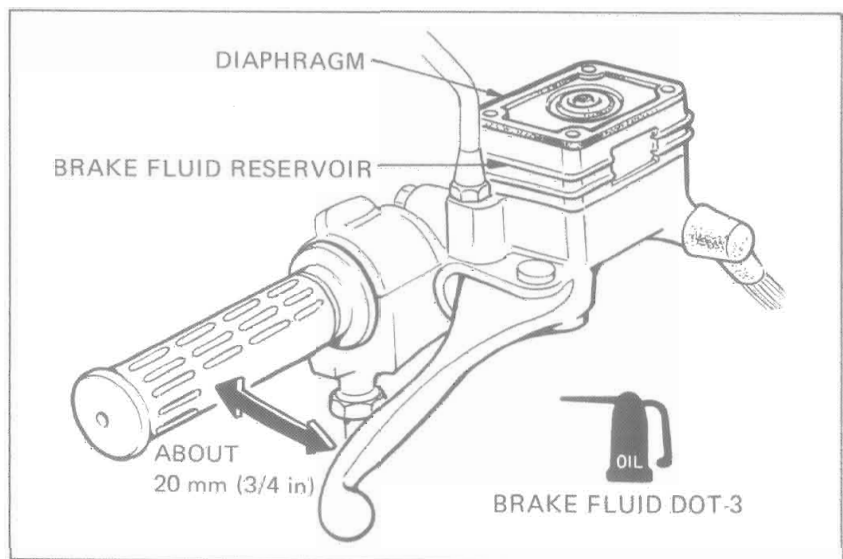



● **BRAKE FLUID DRAINING**

Remove the bleeder valve dust cap.
Connect a bleed hose and place one end in a clean container.

Loosen the caliper bleeder valve and pump up the system pressure by operating the brake lever.

Stop operating the lever when no fluid is flowing out of the bleeder valve.

● **BRAKE FLUID FILLING**

CAUTION

*Check the fluid level often while bleeding the brake, to prevent air from being pumped into the system.
Do not mix different brands of fluid since they are not compatible.*

Close the bleeder valve, fill the reservoir, and install the diaphragm.

To prevent piston overtravel and brake fluid seepage, keep a 20 mm space between the lever and the handlebar grip when bleeding the front brake system.

Pump up the system pressure with the lever until there are no air bubbles in the fluid flowing out of the reservoir small hole and lever resistance is felt.

● **AIR BLEEDING**

Pull the brake lever all the way back to the handlebar grip. Open the bleeder valve about 1/2 turn, and close.

NOTE

Do not release the lever until the bleeder valve has been closed.

Release the lever gradually and wait several seconds after it reaches the end of its travel before repeating the above steps. Continue until there are no air bubbles in the fluid flowing out of the bleeder valve.

Fill the reservoir to the UPPER LEVEL MARK.

Check the entire system for leaks by operating the lever.

WARNING

A contaminated brake disc or pads reduces stopping power. Replace contaminated pads, and clean a contaminated disc with a good quality degreasing agent.

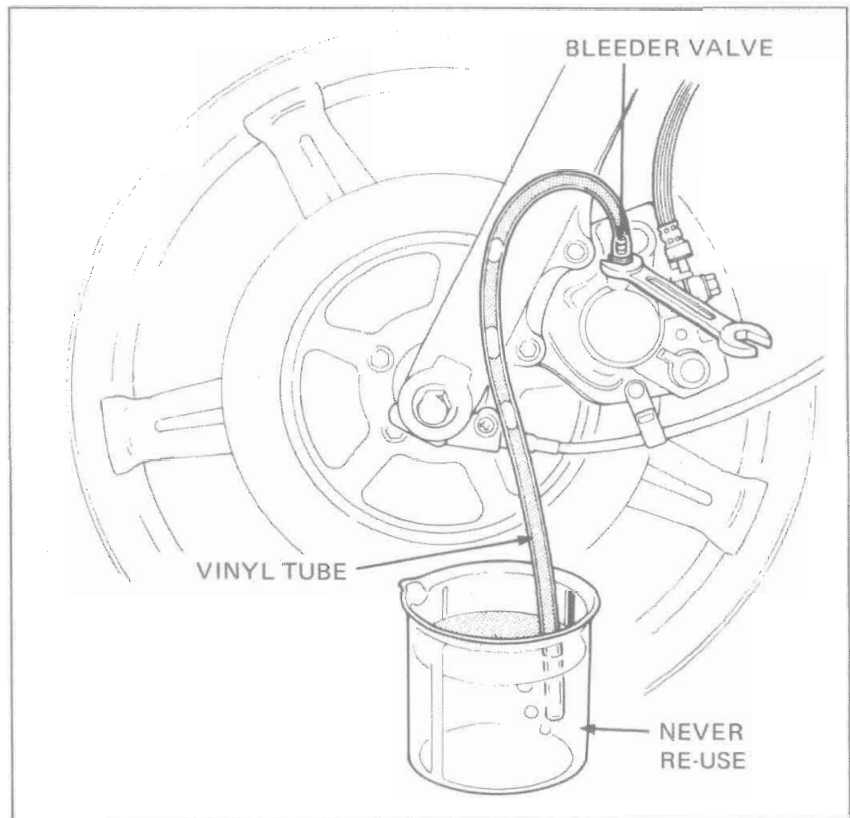



3. FRONT WHEEL/SUSPENSION

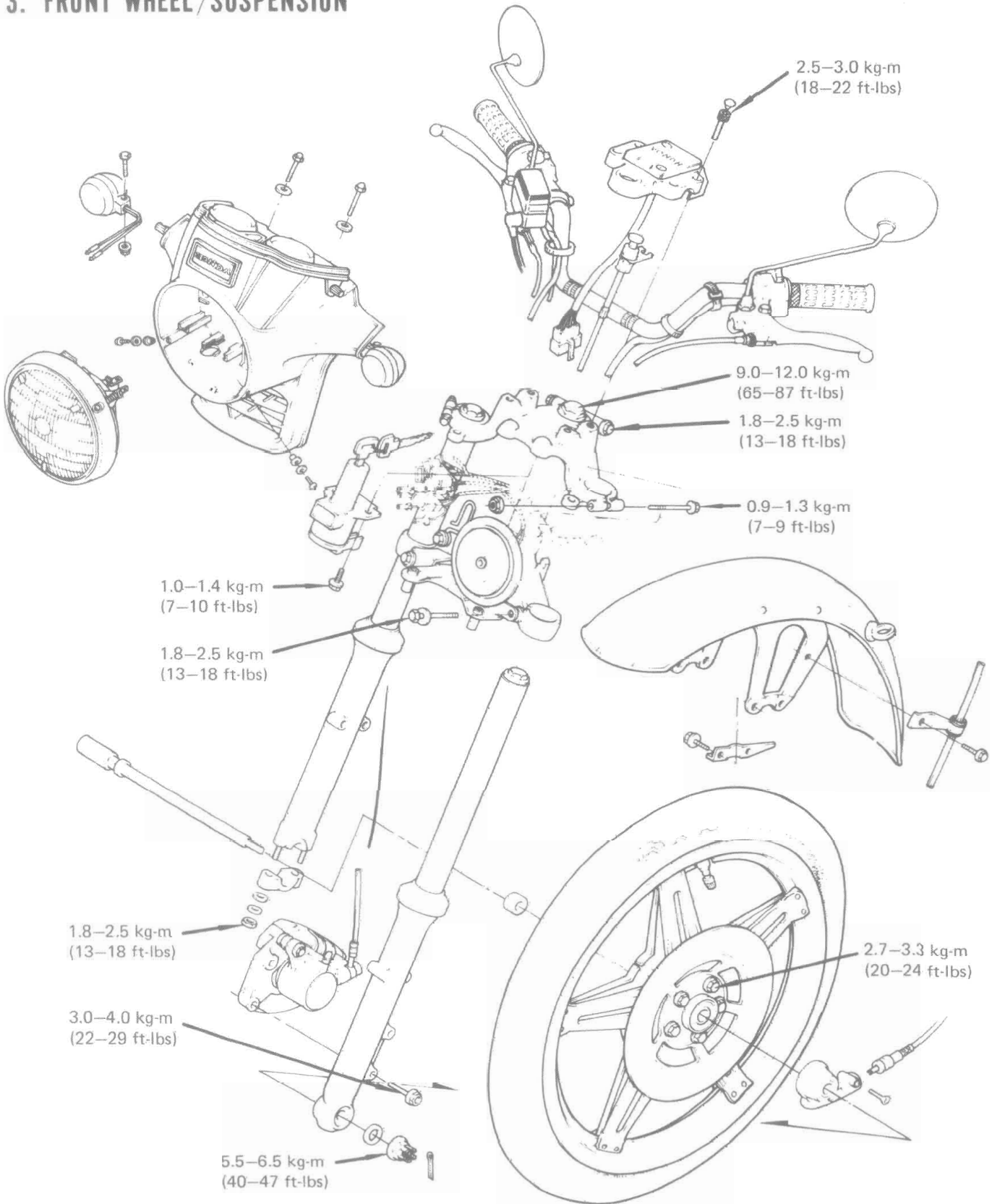



4. HYDRAULIC DISC BRAKE

SERVICE INFORMATION	21-9
TROUBLESHOOTING	21-9
BRAKE MASTER CYLINDER	21-10

SERVICE INFORMATION

• SPECIAL TOOL

SNAP RING PLIERS 07914-3230001

• SPECIFICATIONS

	STANDARDS		SERVICE LIMIT	
	mm	in.	mm	in.
Disc thickness	6.8 - 7.2	(0.27 - 0.28)	6.0	(0.24)
Disc runout	-		0.3	(0.012)
Master cylinder I.D.	14.000 - 14.043	(0.5512 - 0.5529)	14.055	(0.5533)
Master piston O.D.	13.957 - 13.984	(0.5495 - 0.5506)	13.945	(0.5490)
Caliper piston O.D.	42.772 - 42.822	(1.6839 - 1.6859)	42.765	(1.6837)
Caliper cylinder I.D.	42.850 - 42.900	(1.6870 - 1.6890)	42.915	(1.6896)

TROUBLESHOOTING

Poor Brake Performance

1. Air bubbles in hydraulic system
2. Worn brake pads
3. Pads fouled or glazed
4. Hydraulic system leaking



BRAKE MASTER CYLINDER

• MASTER CYLINDER DISASSEMBLY

Drain brake fluid from the hydraulic system. Remove the brake lever and rear view mirror from the master cylinder. Disconnect and secure the brake hose.

CAUTION

Avoid spilling brake fluid on painted surfaces.

Place a rag over the fuel tank whenever the brake system is serviced.

NOTE

Cover the end of the hose to prevent contamination.

Remove the master cylinder.

Remove the snap ring.

Clean the interior of the master cylinder and reservoir with brake fluid.

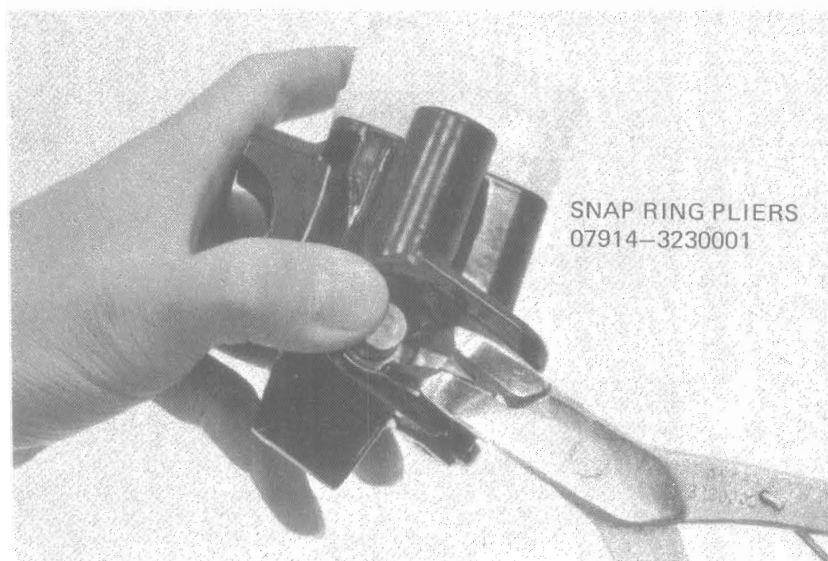
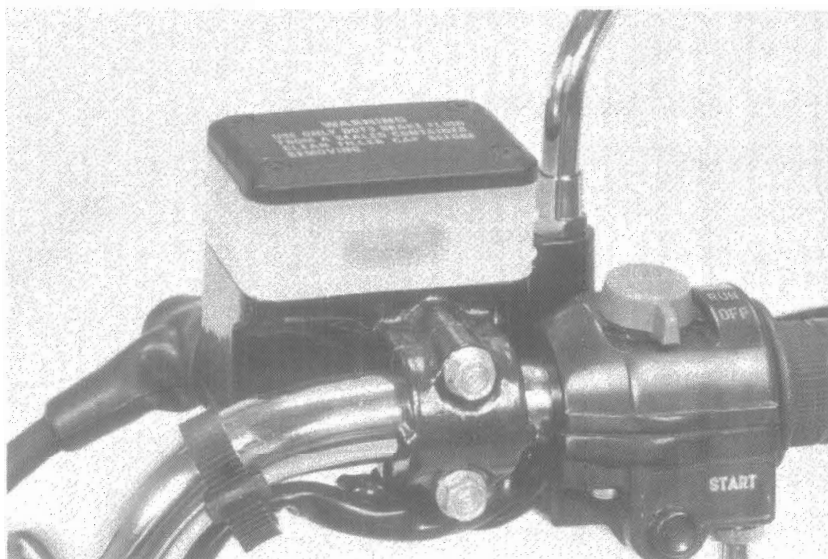

SNAP RING PLIERS
07914-3230001

• MASTER CYLINDER I.D. INSPECTION

Measure the master cylinder I.D.

Check the master cylinder for scores, scratches or nicks.

SERVICE LIMIT: 14.055 mm (0.5533 in)

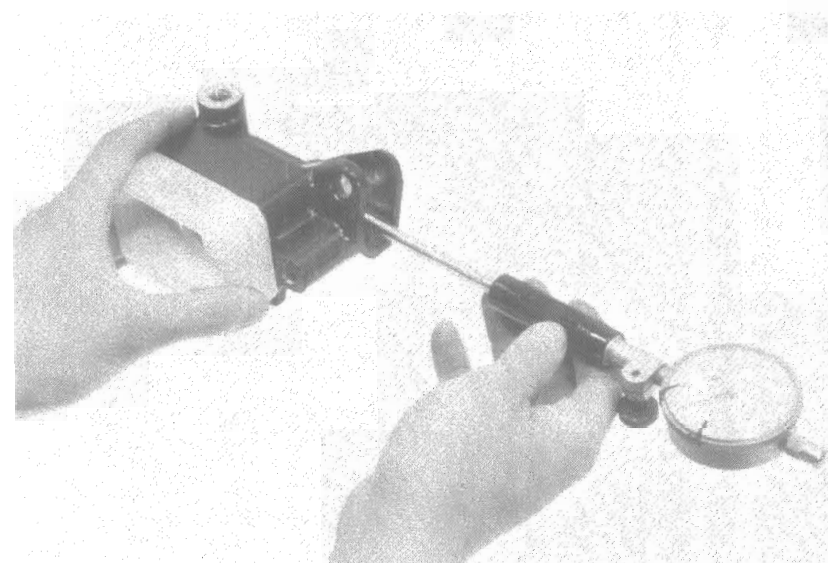



• MASTER CYLINDER PISTON O.D. INSPECTION

Measure the master cylinder piston O.D.

SERVICE LIMIT: 13.945 mm (0.5490 in)

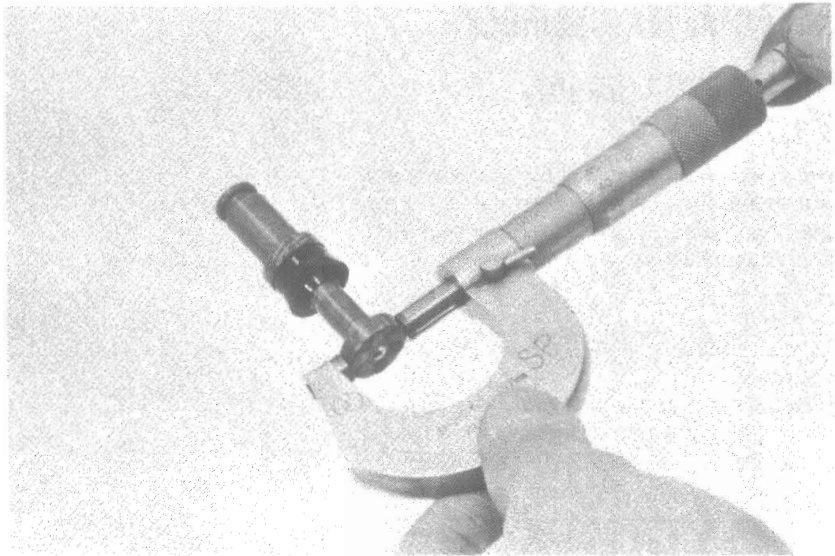

• MASTER CYLINDER ASSEMBLY

CAUTION

Replace the master cylinder piston, cylinder and spring as a set.

Assemble the master cylinder. Coat all parts with clean brake fluid before assembly. Insert the spring into the master cylinder. Dip the piston cup in brake fluid before assembly.

CAUTION

When installing the cups, do not allow the lips to turn inside out. Be certain the circlip is seated firmly in the groove.

Install the boot, washer and clip.
Install the reservoir on the master cylinder making sure that the O-ring is in good condition.

