



17. IGNITION SYSTEM

SERVICE INFORMATION	17-1
TROUBLESHOOTING	17-2
SPARK PLUG	17-3
IGNITION COIL	17-3
C.D.I. UNIT	17-4
A.C. GENERATOR	17-5
ADVANCE PULSER	17-6
IGNITION TIMING CHECK	17-6

SERVICE INFORMATION

• WORKING PRACTICE

Ignition timing cannot be adjusted since the C.D.I. (Capacitive Discharge Ignition) unit is non-adjustable. If ignition timing is incorrect, check the C.D.I. unit and AC generator and replace any defective part.

• SPECIFICATIONS

Spark plug		X24ES-U (ND), D8EA (NGK)
Spark plug gap		0.6-0.7 mm (0.024-0.028 in.)
Ignition timing	Initial	15°
	Full advance	37°
	Engine speed (initial)	1,750-2,250 rpm
	Engine speed (full advance)	5,500-6,000 rpm
Ignition coil	3-point spark test	6 mm (0.24 in.) minimum



IGNITION SYSTEM

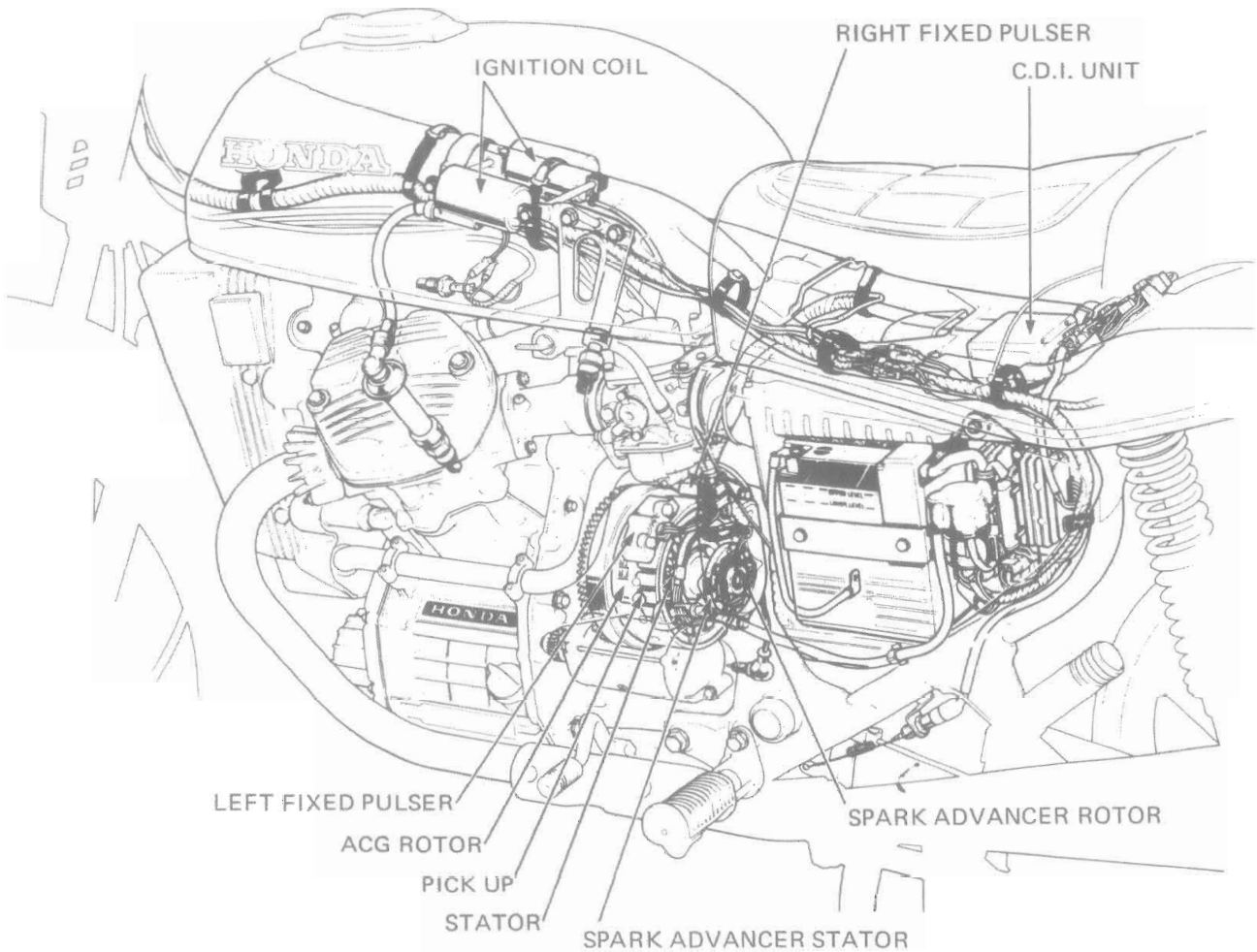

TROUBLESHOOTING

Engine Cranks but Will Not Start:

1. Engine stop switch OFF
2. No spark at plugs
3. Faulty C.D.I. unit
4. AC generator faulty

No Spark at Plugs

1. Engine stop switch OFF
2. Poor connection broken or shorted wires
 - Between AC generator and ignition coil
 - Between C.D.I. unit and engine stop switch
 - Between C.D.I. unit and ignition coil
 - Between C.D.I. unit and ignition switch
 - Between ignition coil and plug
3. Faulty ignition switch
4. Faulty ignition coil
5. C.D.I. Unit faulty
6. Faulty A.C. generator

Engine Starts but Runs Poorly

1. Ignition primary circuit
 - Faulty ignition coil
 - Loose or bare wire
 - Intermittent short-circuit in a switch
2. Secondary circuit
 - Faulty plug
 - Faulty high tension cord
3. Ignition timing
 - Faulty A.C. generator
 - Faulty C.D.I. unit

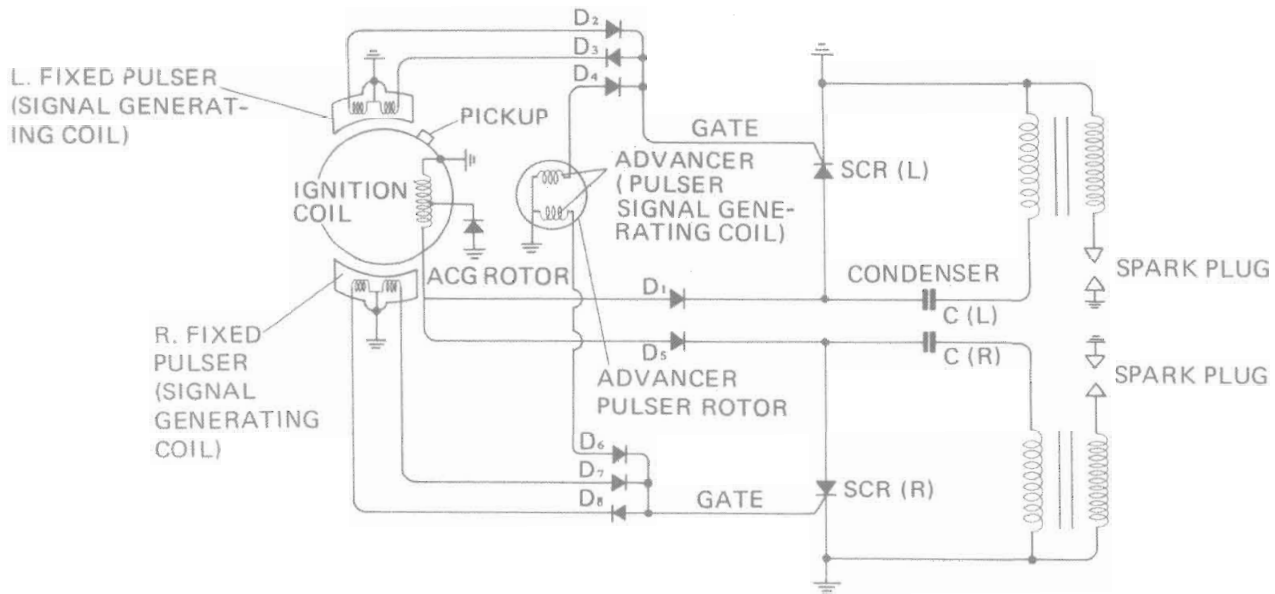

SPARK PLUG

Spark plug gap inspection and adjustment procedure (Page 3-3).

IGNITION COIL

• REMOVAL/INSTALLATION

Remove the fuel tank.
Disconnect the wire leads.
Remove the coil by removing the attaching bolts.

NOTE

Connect the right and left cables properly.

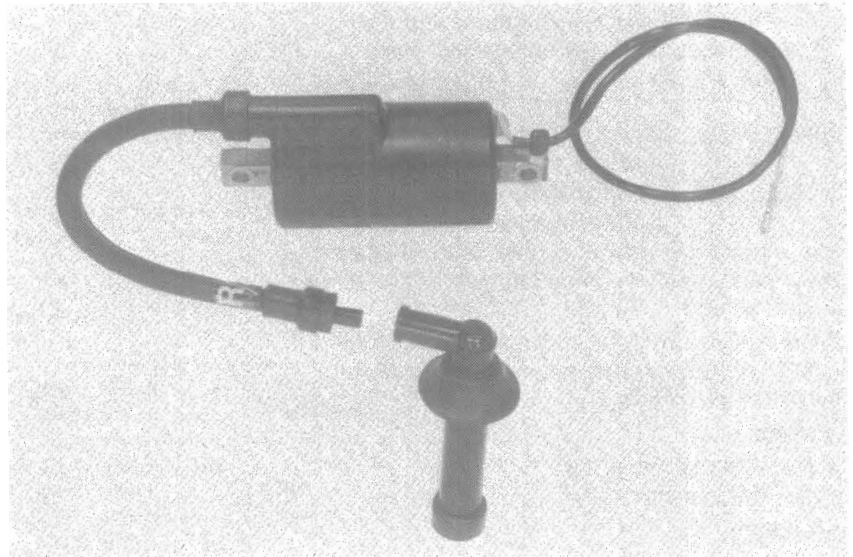

• PERFORMANCE TEST

Perform a 3-point spark test with a coil tester.

NOTE

Follow the instructions supplied with the coil tester.

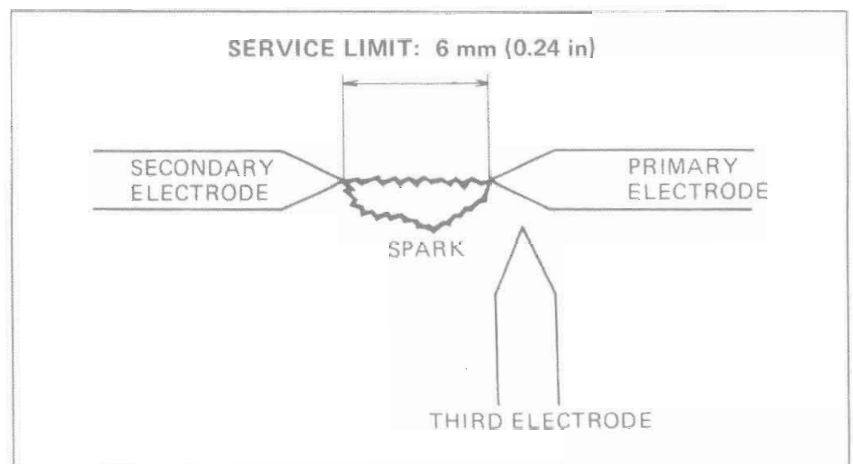



IGNITION SYSTEM

C.D.I. UNIT

• **INSPECTION**

Disconnect wiring. Set the tester at $xk\Omega$ or $x100\Omega$ and check continuity of C.D.I. terminals. Replace the C.D.I. unit if the readings do not fall within the limits shown in the table.

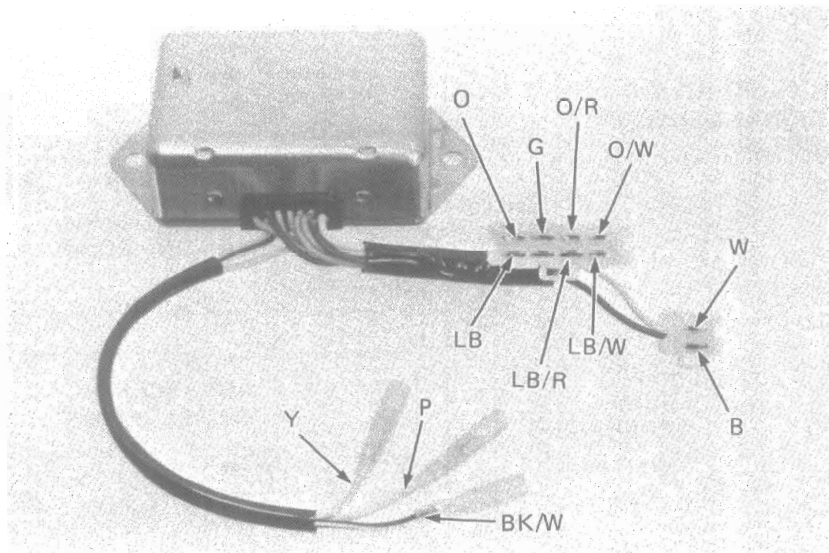

<Fig. 1>

NOTE

- The C.D.I. unit is fully transistorized. For accurate testing, it is necessary to use a specified electrical tester. Use of an improper tester or measurements in improper range may give false readings.
- Use SANWA ELECTRICAL TESTER (SP-10D) P/N 07308-0020000 or KOWA ELECTRICAL TESTER (TH-5H).
- Discharge the capacitor before testing.
- ∇ : Needle swinging and going back to ∞ in the table indicates that a capacitor is being charged with the tester. The tester needle will stay at infinity in subsequent tests unless the capacitor is discharged.

UPPER ROW: MEASURING RANGE (SANWA TESTER) $xk\Omega$
LOWER ROW: MEASURING RANGE (KOWA TESTER) $x100\Omega$

The resistances shown in the table indicate those to be read on the tester, not of specific circuits or parts.

The specifications in Fig. 1 are applicable to the C.D.I. unit (Galvanized on the cover) used on the following models;

<CX500>

F. No. ~CX500-2051739

F. No. CX500-21XXXXX

<CX500C>

F. No. PC01-20XXXXX

F. No. ~PC01-2111953

<CX500D>

F. No. PC01-40XXXXX

GALVANIZED

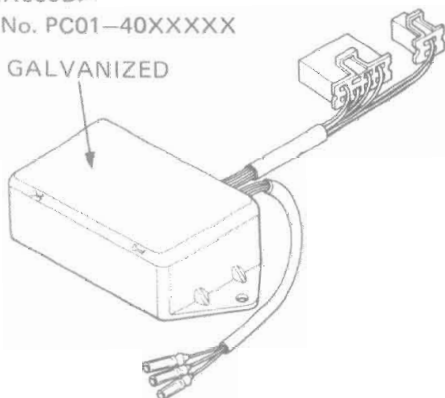

- probe	W	B	LB	O	LB/R	O/R	G	LB/W	O/W	P	Y	BK/W
+ probe	W	500 ~∞	10 ~ 20 20 ~ 60	10 ~ 20 20 ~ 60	500 ~∞	500 ~∞	3 ~ 8	10 ~ 20 20 ~ 60	10 ~ 20 20 ~ 60	500 ~∞	500 ~∞	500 ~∞
B	500 ~∞	500 ~∞	500 ~∞	500 ~∞	500 ~∞	500 ~∞	3 ~ 8 5 ~ 20	10 ~ 20 20 ~ 100	10 ~ 20 20 ~ 100	500 ~∞	500 ~∞	500 ~∞
LB	500 ~∞	500 ~∞	500 ~∞	500 ~∞	500 ~∞	500 ~∞	3 ~ 8 5 ~ 20	10 ~ 20 20 ~ 100	10 ~ 20 20 ~ 100	500 ~∞	500 ~∞	500 ~∞
O	500 ~∞	500 ~∞	500 ~∞	500 ~∞	500 ~∞	500 ~∞	3 ~ 8 5 ~ 20	10 ~ 20 20 ~ 100	10 ~ 20 20 ~ 100	500 ~∞	500 ~∞	500 ~∞
LB/R	500 ~∞	500 ~∞	10 ~ 20 20 ~ 60	10 ~ 20 20 ~ 60	500 ~∞	500 ~∞	3 ~ 8 5 ~ 20	10 ~ 20 20 ~ 100	10 ~ 20 20 ~ 100	500 ~∞	500 ~∞	500 ~∞
O/R	500 ~∞	500 ~∞	10 ~ 20 20 ~ 60	10 ~ 20 20 ~ 60	500 ~∞	500 ~∞	3 ~ 8 5 ~ 20	10 ~ 20 20 ~ 100	10 ~ 20 20 ~ 100	500 ~∞	500 ~∞	500 ~∞
G	500 ~∞	500 ~∞	3 ~ 8 5 ~ 20	3 ~ 8 5 ~ 20	500 ~∞	500 ~∞	3 ~ 8 5 ~ 20	3 ~ 8 5 ~ 20	3 ~ 8 5 ~ 20	500 ~∞	500 ~∞	500 ~∞
LB/W	500 ~∞	500 ~∞	500 ~∞	500 ~∞	500 ~∞	500 ~∞	500 ~∞	500 ~∞	500 ~∞	500 ~∞	500 ~∞	500 ~∞
O/W	500 ~∞	500 ~∞	500 ~∞	500 ~∞	500 ~∞	500 ~∞	500 ~∞	500 ~∞	500 ~∞	500 ~∞	500 ~∞	500 ~∞
P	500 ~∞	500 ~∞	500 ~∞	500 ~∞	500 ~∞	500 ~∞	500 ~∞	500 ~∞	500 ~∞	500 ~∞	500 ~∞	500 ~∞
Y	500 ~∞	500 ~∞	500 ~∞	500 ~∞	500 ~∞	500 ~∞	500 ~∞	500 ~∞	500 ~∞	500 ~∞	500 ~∞	500 ~∞
BK/W	500 ~∞	10 ~ 20 20 ~ 60	500 ~∞	500 ~∞	500 ~∞	500 ~∞	500 ~∞	500 ~∞	500 ~∞	500 ~∞	500 ~∞	500 ~∞



Specifications in Fig. 2 are applicable to the C.D.I. unit (Cover painted with black) used on following models;

<CX500>

F. No. CX500-2051740~

F. No. CX500-2200013~

<CX500C>

F. No. CX500C-2111954~

F. No. PC01-2114149~

<CX500D>

F. No. PC01-4100012~

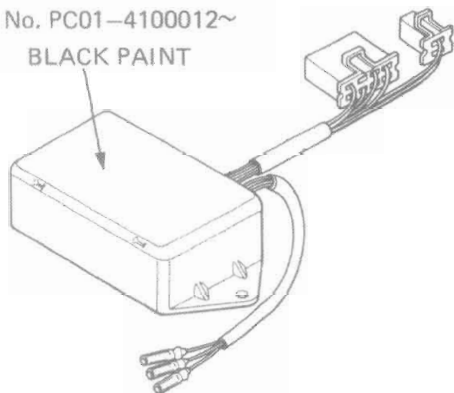

<Fig. 2>

Probe (-)	W	B	LB	O	LB/R	O/R	G	LB/W	O/W	P	Y	BK/W
Probe (+)												
W		500 ~∞	10~20 20~60	10~20 20~60	500 ~∞	500 ~∞	3~8 3~20	10~20 20~60	10~20 20~60	500 ~∞	500 ~∞	500 ~∞
B	500 ~∞		500 ~∞	500 ~∞	500 ~∞	500 ~∞	500 ~∞	500 ~∞	500 ~∞	500 ~∞	500 ~∞	500 ~∞
LB	500 ~∞	500 ~∞		500 ~∞	500 ~∞	500 ~∞	500 ~∞	500 ~∞	500 ~∞	500 ~∞	500 ~∞	500 ~∞
O	500 ~∞	500 ~∞	500 ~∞		500 ~∞	500 ~∞	500 ~∞	500 ~∞	500 ~∞	500 ~∞	500 ~∞	500 ~∞
LB/R	500 ~∞	500 ~∞	10~20 20~60	10~20 20~60		500 ~∞	3~8 5~20	10~20 20~100	10~20 20~100	500 ~∞	500 ~∞	500 ~∞
O/R	500 ~∞	500 ~∞	10~20 20~60	10~20 20~60	500 ~∞		3~8 5~20	10~20 20~100	10~20 20~100	500 ~∞	500 ~∞	500 ~∞
G	500 ~∞	500 ~∞	3~8 5~20	3~8 5~20	500 ~∞	500 ~∞		3~8 5~20	3~8 5~20	500 ~∞	500 ~∞	500 ~∞
LB/W	500 ~∞	500 ~∞	500 ~∞	500 ~∞	500 ~∞	500 ~∞	500 ~∞		500 ~∞	500 ~∞	500 ~∞	500 ~∞
O/W	500 ~∞	500 ~∞	500 ~∞	500 ~∞	500 ~∞	500 ~∞	500 ~∞	500 ~∞		500 ~∞	500 ~∞	500 ~∞
P	500 ~∞	∞	∞	∞	500 ~∞	500 ~∞	∞	∞	∞		∞	500 ~∞
Y	500 ~∞	∞	∞	∞	500 ~∞	500 ~∞	∞	∞	∞	500 ~∞		500 ~∞
BK/W	500 ~∞	20~100 100~500	500 ~∞	500 ~∞	500 ~∞	500 ~∞	500 ~∞	500 ~∞	500 ~∞	∞	∞	500~∞ 500~∞

A.C. GENERATOR

• INSPECTION

Disconnect the stator wires at their connections.

Measure resistances between the terminals:

WHITE-BLUE: 77-95 Ohms

GREEN-WHITE: 387-473 Ohms
(315-385 Ohms)

ORANGE-GREEN: 95-116 Ohms

LIGHT BLUE-GREEN: 95-116 Ohms

ORANGE/RED-GREEN: 81-99 Ohms

LIGHT BLUE/RED-GREEN: 81-99 Ohms

NOTE

- TESTER MEASURING RANGE: x10Ω
 - Use the HONDA SERVICE TESTER (07308-0020000) to perform this test.
 - The specifications in parentheses are applicable to the A.C. generator used on the following models;
- <CX500>
E. No. CX500E-2049947~
E. No. CX500E-2200013~
- <CX500C>
E. No. PC01E-2002941~
E. No. PC01E-2114151~
- <CX500D>
E. No. PC01E-4001273~

A.C. Generator removal and installation procedures (Section 8).

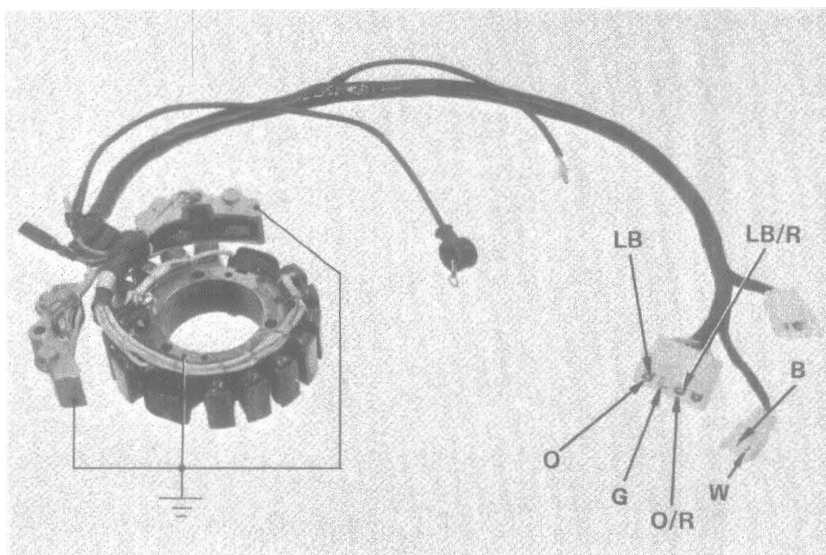



IGNITION SYSTEM

ADVANCE PULSER

• **INSPECTION**

Disconnect the advance pulser coupler.

Measure the resistance of stator coil.
ORANGE/WHITE-GREEN: 185-225Ω
LIGHT BLUE/WHITE-GREEN: 185-225Ω

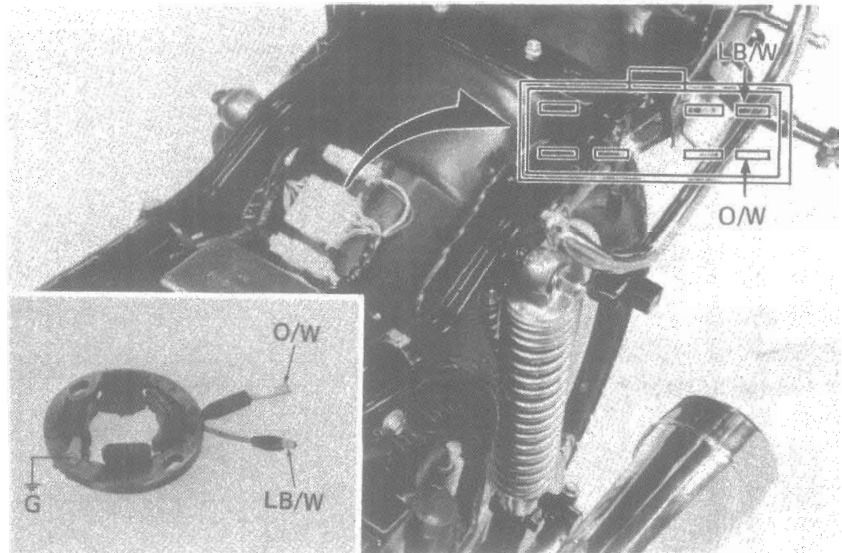

IGNITION TIMING CHECK

NOTE

The C.D.I. (capacitive discharge ignition) ignition timing is not adjustable. If the ignition timing is incorrect, check the C.D.I. unit and A.C. Generator.

Remove the timing hole inspection cap from the engine case rear cover.
Connect a stroboscopic timing light to the right cylinder. Connect a tachometer.
Check that the flywheel "FR" mark and pulser index mark align at idle.
Check that the index mark is between the advance marks at 5,500-6,000 rpm.
Repeat for the left cylinder using the "FL" reference mark.

